

MOSCA[®]

EXCELLENCE IN STRAPPING SOLUTIONS

EVOLUTION

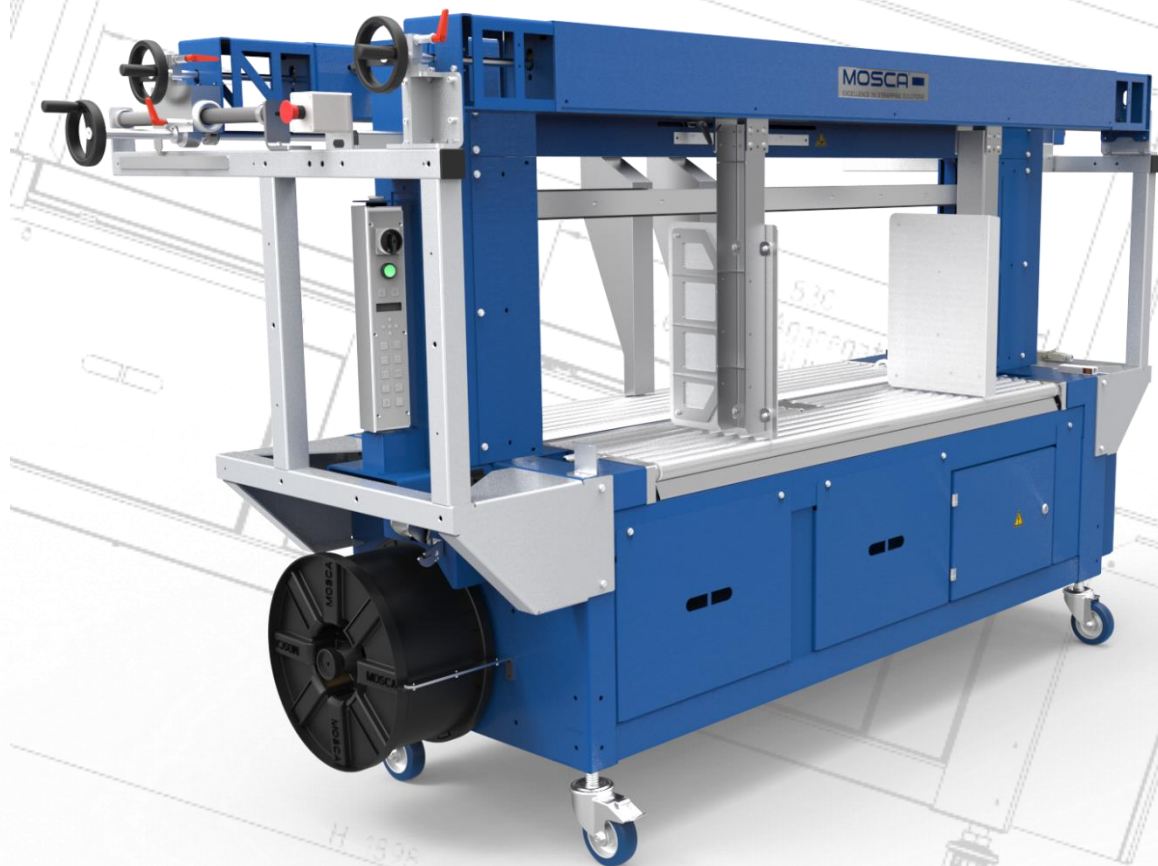

SoniXs TRC-6-Q

**Fully Automatic Strapping Machine with
Integrated Squaring Device**

SoniXs TRC-6-Q

MACHINE DESCRIPTION

- Symmetrical design of the conveying system to the strapping level
- Easy accessibility and tool-free disassembly of strap way components
- Tool-free disassembly of roller system
- Easy operation over digital display in the control panel
- High-end Standard 6 sealing unit
- Ultrasonic sealing system with electronic self calibration
- Bundle positioning via increments by metrical input of the strapping positions
- Pneumatic hold down device with manual repositioning
- Transport by aluminum rollers
- Pneumatic backstop with manual repositioning
- Safety circuit for up-stream and down-stream systems
- Pneumatic side pushers
- Selector switch for single, double or multiple strapping
- Quick strap coil change
- Fully automatic strap threading
- Defined strap end detection with ejection of remaining strap
- Automatic strap loop ejection when machine cycles without bundle
- Structural coating RAL 5010 gentian blue

OPTIONS

- Fully automatic double dispenser
- Traffic light warning system including low strap indication
- Special working height + 200 mm
- Table extension
- Floor rails for easy movement

TECHNICAL DATA

PERFORMANCE:

Machine Type	TRC1650
Frame Size	1650x600
Single strapping (up to)	22 bundles per minute
Double strapping (up to)	12 bundles per minute

STRAPS:

Standard machine grade: 5, 6, 8, 9, 10 or 12 mm wide PP straps

STRAP COIL DISPENSER:

Core diameter	200 mm
Core width	190 mm
Max. outside diameter:	430 mm

ELECTRICITY:

Network data: 100 - 240 V, 50/60 Hz, 1 PH*
Power consumption: approx. 0.4 kW

* Country specific adaption possible

PNEUMATICS:

Operating Pressure: 6 bar (1/4 inch rapid clutch)
Air Consumption: 15.1 NI/cycle; with pneumatic hold-down device, backstop and sidepushers

WEIGHT:

~ 780 kg (1650 x 600 mm, with hold-down device, backstop and sidepushers)

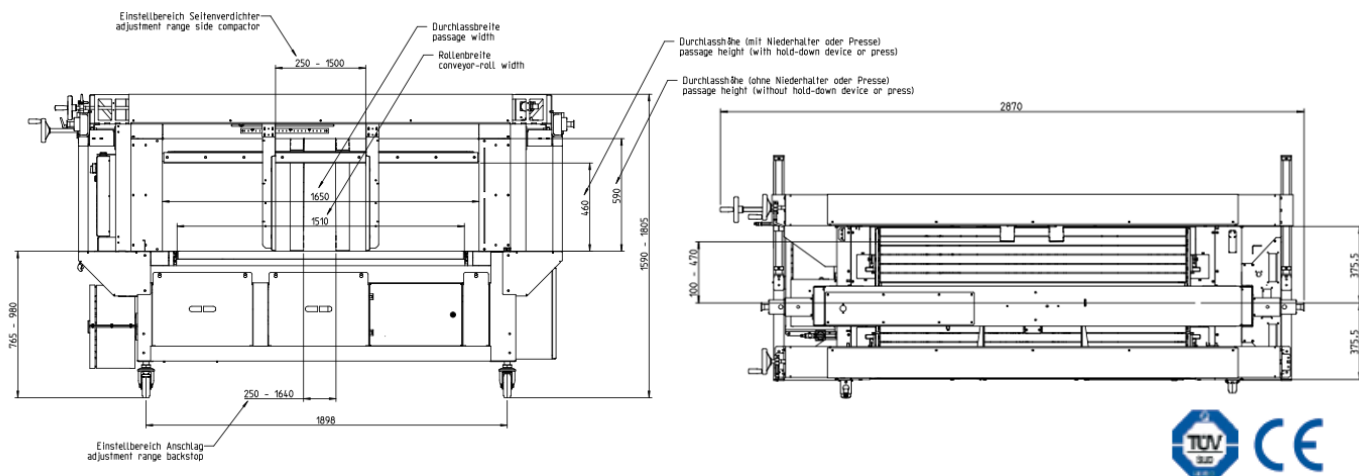

MOSCA
EXCELLENCE IN STRAPPING SOLUTIONS

Mosca Asia Pte. Ltd
28 Genting Lane, #08-02,
Platinum 28
Singapore 349585
SINGAPORE
Tel: +65 6509 7908
Fax: +65 6636 5711
E-Mail: asia@mosca.com

07/16 Subject to alterations

The models of SoniXs TRC-6-Q are adjustable to one strap width of all quality PP straps between 5 and 12 mm. Obtainable directly from Mosca, manufactured to the highest standards on sophisticated production lines.

