

KONGSBERG X EDGE & C EDGE

Exceptional cutting quality at a remarkable price

Enter the world of digital finishing with the **Kongsberg X Edge** and the **Kongsberg C Edge** cutting tables.

Kongsberg Edge cutting tables are the result of over 50 years of technical expertise and innovation. Both series grow with your business, they can be field upgraded to work faster when your company is ready.



Speed & power on demanding materials

The Kongsberg cutting tables offer raw strength required to process even the most rugged materials at high-production speeds, without slowing down or compromising finishing quality.



Versatility

The Kongsberg cutting tables come with a wide range of tools and offer the highest versatility for all sign, display and packaging applications. Working with just about any substrate, from thin flexibles, to foam, to fluted materials and even rigid boards.



Produce 24/7

The Kongsberg Edge tables are ready to be extended with additional hardware for non-stop automated production.

Kongsberg Edge tables: a perfect fit for every application



Corrugated
packaging



Displays



Signage



Sample making



Labels & decals



Protective
packaging

NO COMPROMISE

- ✓ **Max. material size:** 2270 x 6930 mm (90 x 273 in.)
- ✓ **Max. speed:** 30 m/min (20 IPS)
- ✓ **Max. acceleration:** 0.3 G (3 m/s²)

The Kongsberg X Edge is the perfect start of your digital finishing journey. The tried and tested Kongsberg recipe of **productivity** and **flexibility** combined with best in class **reliability** – no compromise.

The Kongsberg X Edge delivers speeds of 30 m/min (20 IPS) with acceleration of 0.3 G (3 m/s²) and can handle the full spectrum of display, signage and packaging materials from kiss cutting vinyl to heavy duty milling and everything in between.

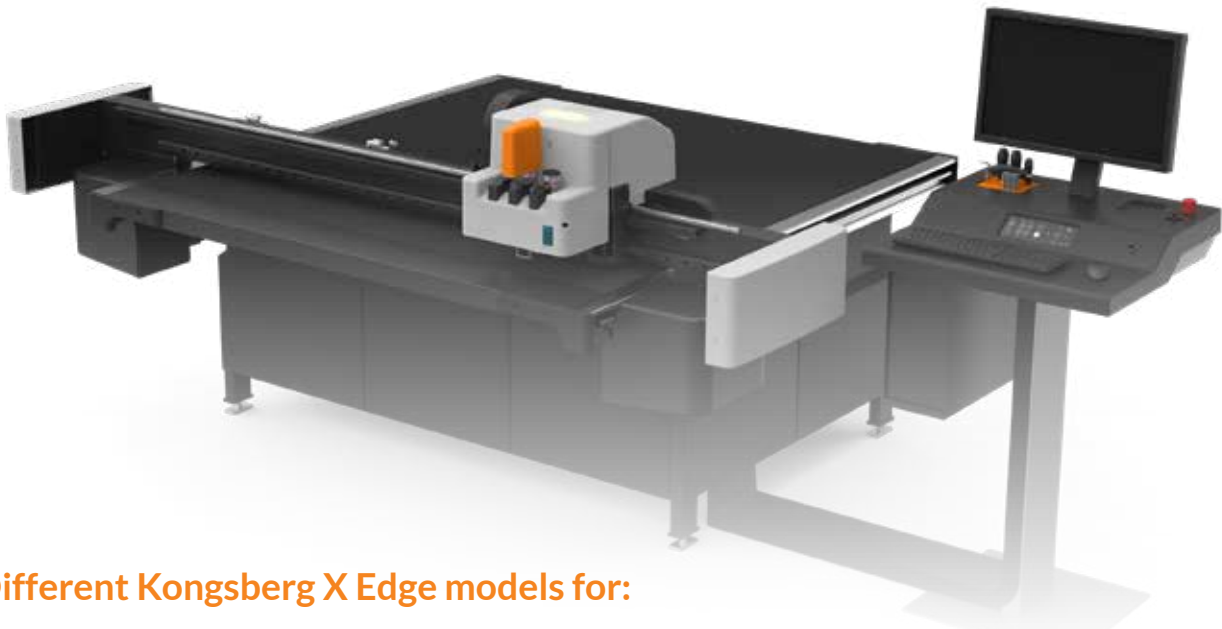

Different Kongsberg X Edge models for:

Short run	Production	Flex
<ul style="list-style-type: none"> ⊕ For sample making, short run production and other packaging-related tasks ⊕ Production on a wide range of materials, with fewer manual tool changes ⊕ Extra fast tool loading, auto recognition and calibration ⊕ Available with felt or PVC underlay 	<ul style="list-style-type: none"> ⊕ For signage, packaging or display production ⊕ Great quality for any job or application ⊕ Ability to add a conveyor system to support automated board & roll feeding ⊕ A variety of milling options to match your throughput requirements ⊕ Perfect print-to-cut registration, even in cases of heavy distortion and jobs longer than the table 	<ul style="list-style-type: none"> ⊕ Cutting of flexo plates and patches ⊕ Operates back to back with your imaging device, physically and digitally ⊕ Fits in a truly tailored workflow defined together with Esko's Digital Flexo team ⊕ Can also be equipped to produce dedicated shipping boxes for your finished plates

EXCEPTIONAL QUALITY AT A REMARKABLE PRICE

- ✓ **Max. material size:** 3330 x 5330 mm (131 x 210 in.)
- ✓ **Max. speed:** 75 m/min (49 IPS)
- ✓ **Max. acceleration:** 1 G (9.8 m/s²)

Enter the world of 24/7 digital finishing with the Kongsberg C Edge, ideal for all your sign and corrugated production.

Step up your productivity with its high speed (75m/min, 49 IPS) and acceleration (1 G, 9.8 m/s²), and astound your customers with impressive, **high quality results** and **fast turnarounds**.

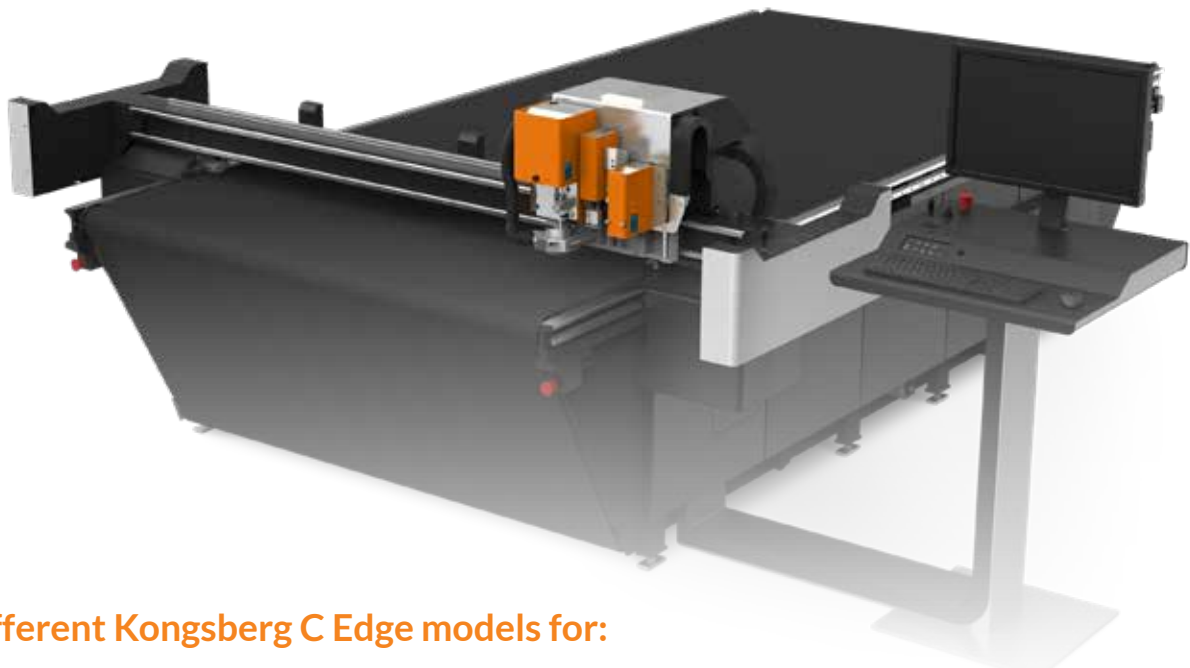

Different Kongsberg C Edge models for:

Signage production	Corrugated production
⊕ Produce using a wide range of materials	⊕ Powerhead for heavy duty production with 50 kg downforce
⊕ Fewer manual tool changes with extra fast tool position	⊕ High quality crease lines with 150 mm crease wheel
⊕ Consistent milling accuracy	⊕ CorruSpeed tool for cut quality excellence at 100% speed
⊕ Available with or without conveyor	⊕ Available with or without conveyor

Upgrade your Kongsberg Edge cutting table

Upgrade the Kongsberg Edge cutting tables for even **more speed & throughput**.

As your company grows, the Kongsberg Edge cutting table can be easily field-upgraded. Make sure your production can keep up, boost the table's speed and acceleration to new heights!

	Kongsberg X Edge	Kongsberg X	Kongsberg C Edge	Kongsberg C
Max. speed	30 m/min (500 mm/sec) 20 IPS	→ 50 m/min (833 mm/sec) 33 IPS	75 m/min (1250 mm/sec) 49 IPS	→ 100 m/min (1666 mm/sec) 66 IPS
Max. acceleration	0.3 G 3 m/s ²	→ 0.56 G 5.5 m/s ²	1 G 9.8 m/s ²	→ 1.72 G 16.8 m/s ²

Don't forget: worldwide service, right around the corner

When you invest in a Kongsberg table you can expect the **highest level of service** in the market.

Our highly experienced engineers and a network of certified service partners are dedicated to maintaining production uptime, wherever you are located.

Want to know more?

Visit www.kongsbergsystems.com, or talk to a specialist at:

Europe, the Middle-East & Africa: info.eur@kongsbergsystems.com
Americas: info.na@kongsbergsystems.com
Asia Pacific: info.apac@kongsbergsystems.com

Europe Kortrijksesteenweg 1087-B, 9051 Gent | info.eur@kongsbergsystems.com

Americas 8535B Gander Creek Drive, Suite B, Miamisburg, OH 45342 | info.na@kongsbergsystems.com

Asia Pacific 100 TRAS Street, #16-01 100 AM, Singapore 079027 | info.apac@kongsbergsystems.com

kongsbergsystems.com

KONGBERG
Precision Cutting Systems